

DO NOT SCALE THE DRG. ASK IF IN DOUBT. REMOVE SHARPE EDGES

0.012 / 0.025 / 0.05 / 0.1 / 0.2 / 0.4 / 0.8 / 1.6 / 3.2 / 6.3 / 12.5 / 25 / 50 / 100

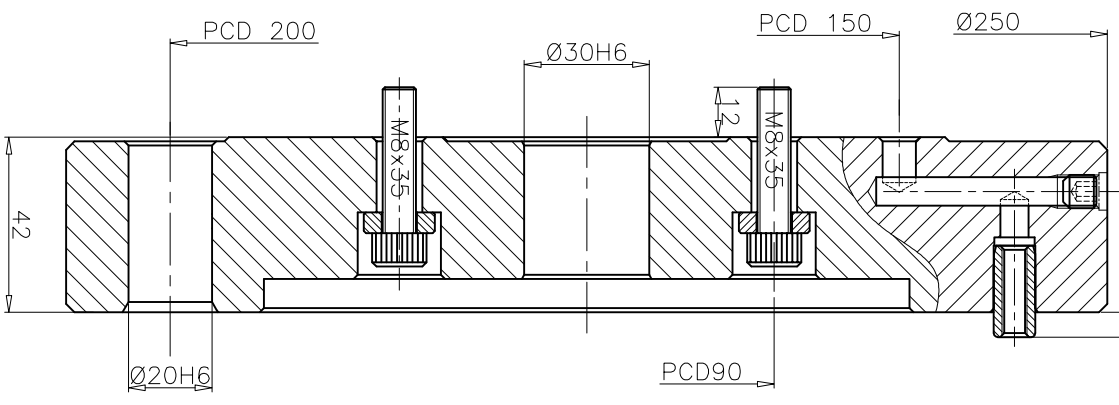
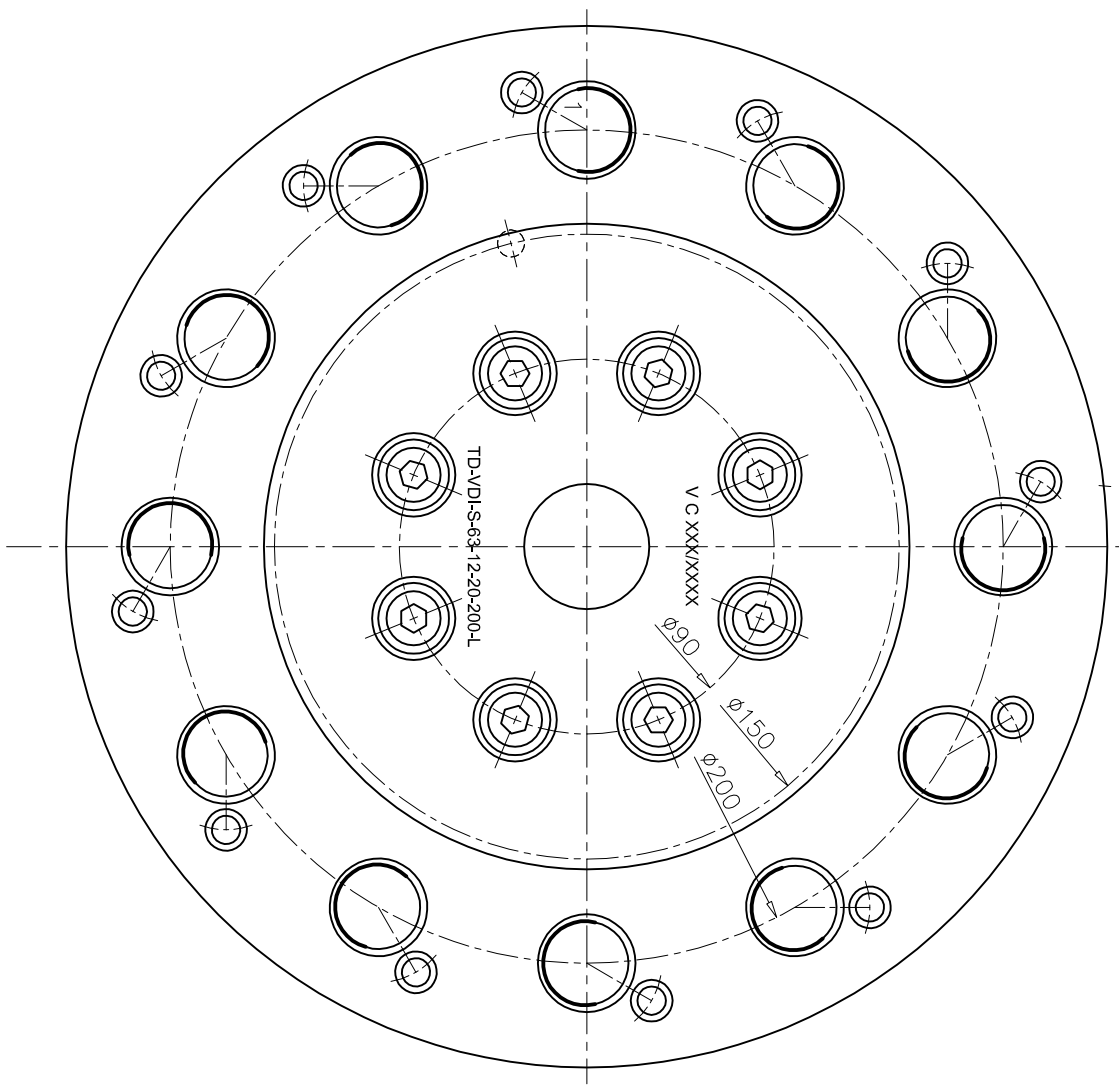

MACHINING DEVIATIONS WHERE NOT SPECIFIED

From	Unit	Deviation	Length of Surface	Angular Dimension	Deviation in
6	30	±0.2	Above	100 mm	mm
30	120	±0.3	Above	10	mm
120	315	±0.5	10	±1.8	°
315	1000	±1.2	50	±0.9	mm
1000	2000	±1.2	50	±0.9	mm
2000	2600	±1.2	50	±0.3	mm

TD-VDI-S-63-12-20-200-L

SCALE: NTS

THE INFORMATION CONTAIN HEREIN IS THE EXCLUSIVE PROPERTY OF SPHOORNI MACHINE TOOL PVT. LTD. & SHALL BE TREATED AS CONFIDENTIAL.

**SPHOORNI**  
BANGALORE

Doc no. \_\_\_\_\_  
Date \_\_\_\_\_

by PAVAN  
DRAWN VDI GROUP TD  
CHECKED P. SEKAR  
APPROVED 07-04-15

DRAWING No. SDF17001

REV SHEET 01 010F01