

DO NOT SCALE THE DRG. ASK IF IN DOUBT. REMOVE SHARPE EDGES

0.012 / 0.025 / 0.05 / 0.1 / 0.2

0.4 / 0.8 / 1.6 / 3.2 / 6.3 / 12.5 / 25 / 50 / 100

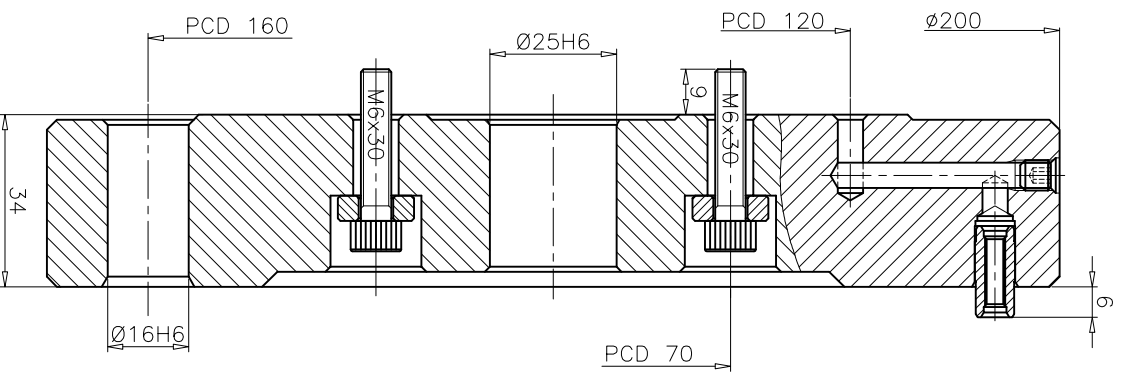
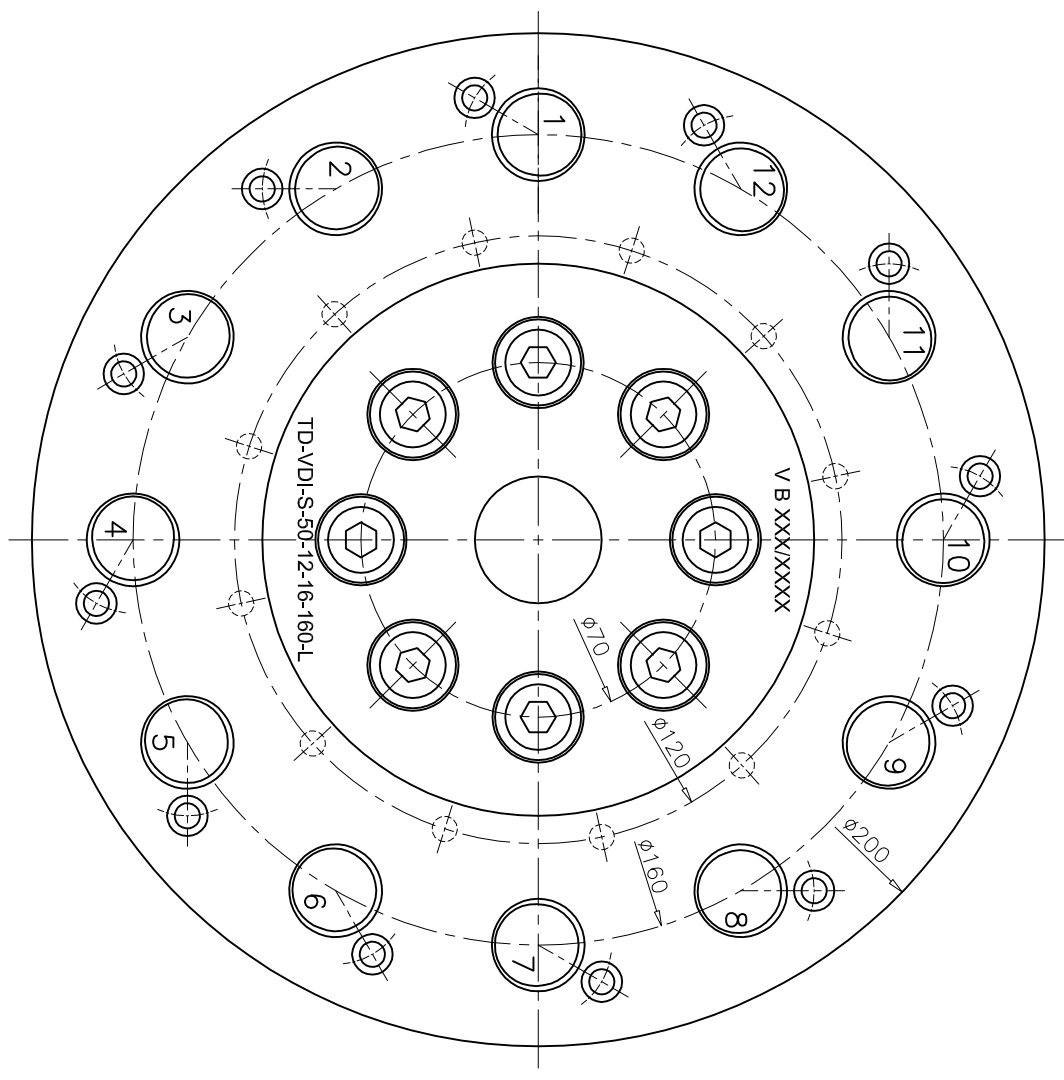

MACHINING DEVIATIONS WHERE NOT SPECIFIED

From	Unit	Deviation	Length of Spline	Angular Dimension
6	mm	±0.2	Above	mm
30	mm	±0.3	Above	mm
120	mm	±0.5	Above	mm
170	mm	±0.5	Above	mm
1000	mm	±1.2	Above	mm
120	mm	±0.3	Above	mm
120	mm	±0.3	Above	mm

THE INFORMATION CONTAIN HEREIN IS THE EXCLUSIVE PROPERTY OF SPHONORNI MACHINE TOOL PVT. LTD. & SHALL BE TREATED AS CONFIDENTIAL

SPHONORNI
BANGALORE

MODEL VDI GROUP TD

Doc no. 22-04-11

by D.JAYA

SCALE NTS

TD-VDI-S-50-12-16-160-L

DRAWING No. 22-04-11

SD30801

REV SHEET 01 010F01